



PRODUCTS CATALOG

ELECTRICAL ENCLOSURES & MODULAR CABINETS



20

NEMA 12-13 ENCLOSURES

5500 ESDD

OIL & DUST TIGHT DOUBLE DOOR ENCLOSURE

The 5500 ESDD wall mounted double door, oil and dust tight enclosures are used indoors for protection against dirt, dust and oil. The box and cover are made of high quality 14 GA steel, with all seams continuously welded. The opening has a curled lip around all sides, and there is no center post. The left hand door is flanged and

the 3-point locking handle is on the right hand door. The captive pins of the concealed hinges can be easily pulled to remove the door. Wall mounting feet are optionally available. **Each enclosure comes complete with a 12 GA inner panel**, which mounts on welded M8 studs. Enclosures are finished with heat fused powder paint, electrostatically applied

on a pretreated base. Box is ANSI/ASA 61 gray, inner panel is galvanized.

**CSA Certified / UL Listed
NEMA/EEMAC 12-13 / IP55**

Refer to p.734 to validate choice of substrate for the application

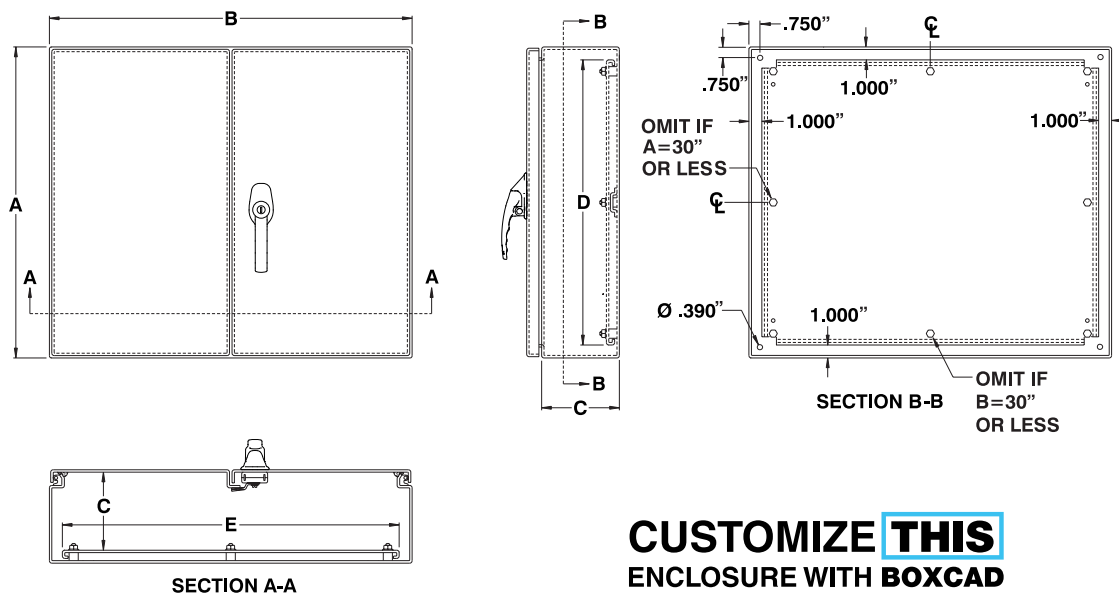

CUSTOMIZE THIS
ENCLOSURE WITH **BOXCAD**
SIZE - COLOR - CUT-OUTS



CATALOG NUMBER	DIMENSIONS					SHIP WGHT LBS.
	A	B	C	D	E	
5500 ESDD244208	24	42	8	22	40	117
5500 ESDD244808	24	48	8	22	46	130
5500 ESDD544208	54	42	8	52	40	272
5500 ESDD244210	24	42	10	22	40	150
5500 ESDD304210	30	42	10	28	40	152
5500 ESDD304810	30	48	10	28	46	168
5500 ESDD306010	30	60	10	28	58	203
5500 ESDD364212	36	42	12	34	40	220
5500 ESDD364812	36	48	12	34	46	242
5500 ESDD366012	36	60	12	34	58	292
5500 ESDD424212	42	42	12	40	40	197
5500 ESDD424812	42	48	12	40	46	216
5500 ESDD426012	42	60	12	40	58	349
5500 ESDD484812	48	48	12	46	46	225



Insulated box? To have your enclosure insulated, add suffix "TH"

i.e.: 5500 ESDD426012TH → Insulated steel enclosure

250

